

Vedar Door



Installation instructions for Timber Sectional doors



ATTENTION! GENERAL WARNINGS!

To install, use and maintain this door safely, a number of precautions must be taken. For the safety of all concerned pay heed to the warnings and instructions given below! If in doubt, contact your supplier.

1. This manual has been written for use by experienced fitters and as such is not suitable for d.i.y. purposes or for use by trainee fitters.
2. This manual describes the installation of the hardware set components, door sections (panels) and refers to installation manuals of the electrical operator. Be sure to supplement this manual if needed with instructions for any additional components not described in this manual.
3. Before starting, read this manual carefully!
4. Certain components may be sharp or have jagged edges. As such you are advised to wear safety gloves.
5. All the components which have been supplied are designed for use with this specific overhead door. Replacement or adding additional components may have an adverse effect on the safety of, and the guarantee on, the door. Also the CE-approval which has been granted to this door will be cancelled when components are changed or installation is not done according to this manual! Installer is responsible for this.
6. During tensioning, springs can exert large forces. Work carefully. Use the proper equipment. Ensure that you are standing in a steady position.
7. Ensure that there is sufficient light during installation. Remove obstacles and dirt. Make sure that there is no one else present other than the fitters. Other people (children!) may get in the way or endanger themselves during the installation.
8. **SPECIAL SAFETY WARNINGS OR REMARKS IN THIS MANUAL ARE INDICATED WITH THIS SYMBOL:**  **READ THESE WARNINGS CAREFULLY.**

GUARANTEE, CONDITIONS AND TERMS

The general terms and conditions of delivery and payment issued by the Metaalunie and designated as METAALUNIE CONDITIONS are fully applicable to all our quotations, contracts and their implementation. We expressly reject all other terms and conditions. On request we will send you a copy of these terms and conditions free of charge. A copy may also be downloaded from our website www.flexiforce.nl.

Flexi-Force strives to deliver 100 % in conformance with the order. In practice, in spite of all our controls, this is not always possible. However we will rectify any errors as quickly as possible, in order to minimise the inconvenience caused to you or the user. As such, it is important that you inform us as soon as possible about any problem with the delivery (include the order number and week of production) and give us the opportunity to offer a suitable solution.

Cedar Door will only reimburse third party costs if we have given explicit permission for this in advance. The reimbursement is based on normal rates and travelling expenses over distances of 1 hour away at most. For large-scale projects we strongly advise you to first install 1 door completely before installing the other doors. In this way, any errors can be detected early on and rectified comparatively cheaply.

This manual does not confer any rights. Technical modifications may be made without written notice.

Flexi-Force has endeavoured to design and put together this hardware set in conformance with the applicable CE-norms. However, we recommend to check our configuration against any local national specification.

INDEX

Before Starting the installation:

General warnings and instructions	1
Warranty terms and conditions	3
Introduction	4
Tools required for correct and rapid installation	5
General system drawings	6
<u>Installing</u>	
Installing vertical track	6
Installing ,assembling curve plate springs in rear (R)	6
Fitting cable pulley to side plate(R)	7
Installing ,assembling curve plate springs in front (F)	7
Assembly horizontal track set , fitting top weather seal	8
Assembly bearing plate support and spring package, springs in rear	8
Suspension and connection of horizontal tracks front (F)	9
Suspension and connection of horizontal tracks rear (R)	10
Assembly and fitting of spring package, springs in rear (R)	11
	12
Assembly and fitting of spring package, springs in front (F)	13
	14
Fitting the door panels	15
Installing bottom panel springs in front (F)and rear (R)	16
Placing panels	17
Installation of roller carrier springs in rear (R)	17
Installation of roller carrier springs in front (F)	18
Fitting cable and tensioning the spring package springs in rear (R)	18
Fitting cable and tensioning the spring package springs in front (F)	19
Finishing the door	21
Option electric drive	22

INTRODUCTION

Flexi-Force has developed a completely new hardware set for residential (garage) overhead doors. Designed for all built-in situations depending on the available space. The set includes the following features:

- 1 **Suitable for single and double garages to W x H = 5 x 3m, max.**
- 2 **Spring package behind the horizontal tracks (R), needed head room 70-100mm or**
- 3 **Spring package in front (F) at the lintel, needed head room 200mm.**
- 4 **Fitted with cable within the tracks and spring breaking device meeting CE standards**
- 5 **Restricted installation**
- 6 **CE approved when selecting the proper Flexi-Force compo-**

In this handbook we shall restrict our instructions for the proper assembly of the complete door. For installation of not mentioned products or parts, including any components added by the supplier, as well as for a user handbook, we refer you to the supplier of the complete overhead door who is also responsible for the correct CE marking of the door. These instructions have been prepared for use by experienced professional fitters and are therefore not suitable for the "DIY" fitter or the apprentice fitter.

The article codes of the parts are given in (parentheses). This door can only be installed according to the CE-certificate if all parts are according to the parts lists of the SP-certificate. See www.flexiforce.com.



Flexi-Force has applied the mandated INITIAL TYPE TESTING for doors described in this manual, at the SP-Institute in Sweden (as Notified Body Nr. 0402). The INITIAL TYPE TESTING REPORT that has been rewarded, can be transferred to the door producing company. This is needed to complete your CE files according to product standard EN13241-1.



NB! This garage door cannot be equipped with a pass door (wicket door). All CE-approvals are not valid when a pass door is installed. If you want to include a pass door, a new Initial Type Testing should be arranged under your responsibility.

General (important please read below if any items are missing or damage it must be reported with-in 48hrs)

Receipt and delivery of door.

With a four panel high door you will receive two packages containing panels, one package containing tracks, one package containing fittings and one package containing springs (if not included in track package).

With a five or six panel high door you will receive one extra panel package.

The door panels will be delivered in 2no shrink-wrapped packages each with 2 sections of the door face to face together being separated with a layer of bubble wrap cut away the shrink wrapping carefully taking care not to cut the timber panels, you will find a plywood strip screwed the bottom edge of some of the panels this is to protect the grooved out section of the joining panels from transit damage.

You will also find pre fitted to the panels all side and intimate hinges, bottom roller brackets and bottom weather seal, so the door can be unwrapped and installed into to opening ready to have the rollers fitted, the top roller brackets can only be fitted once all the panels are in place and lined up correctly.

Important When installing the panels into the opening place a piece of cardboard between the panels to provide the correct spacing's between the panels if is not done the timber panels could bind and creek due to Expansion.

TOOLS REQUIRED FOR CORRECT AND RAPID ASSEMBLY

(Battery) drill with Bit 4.0 mm (drilling has to be done with installing the spring breaking device
Also for fixing the rubber stop to the track.)

Bit 6,5 mm

Plug 10 mm

Plug 13 mm

Hexagonal key 4 mm

Ring /open ended spanner 10 mm

Ring /open ended spanner 13 mm

Ring /open ended spanner 15 mm

Ring /open ended spanner 17 mm

Socket wrench with 1/4" drive

Wrench

Gluing clamp

Cord

Water level (hose)

CHECKING DIMENSIONAL DETAILS

Before assembling the set the details below should be checked on the basis of this figure.

Figure 1

A = Clear width

B = Clear height

C = Side area

D = Top area

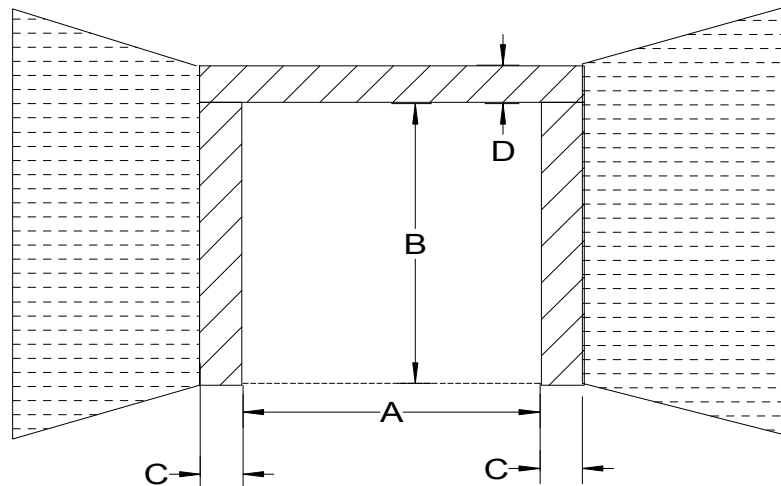
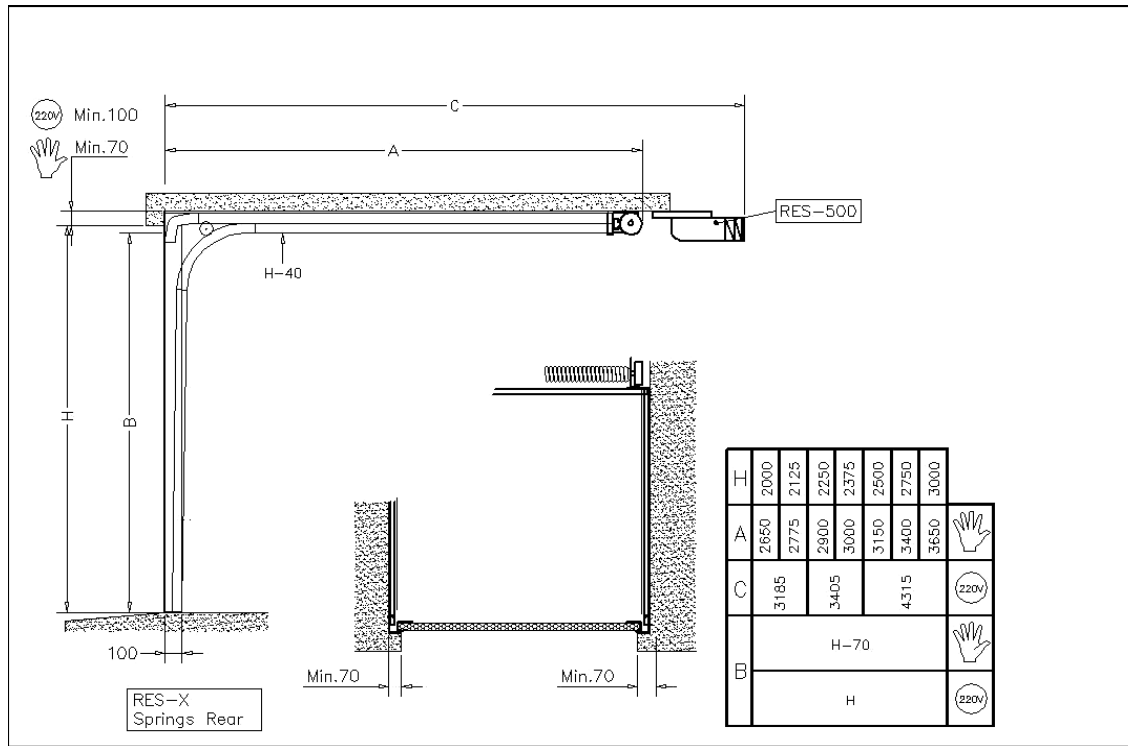

Figure 1

Installation area required

	<u>Springs in front (F)</u>	<u>Springs in rear (R)</u>
Side area C	minimum 70mm	minimum 70mm
Top area D	minimum 200 mm (manual) minimum 200 mm (e-drive)	minimum 70mm (manual)

GENERAL SYSTEM DRAWING SPRINGS IN REAR (R)



GENERAL SYSTEM DRAWING SPRINGS IN FRONT (F)

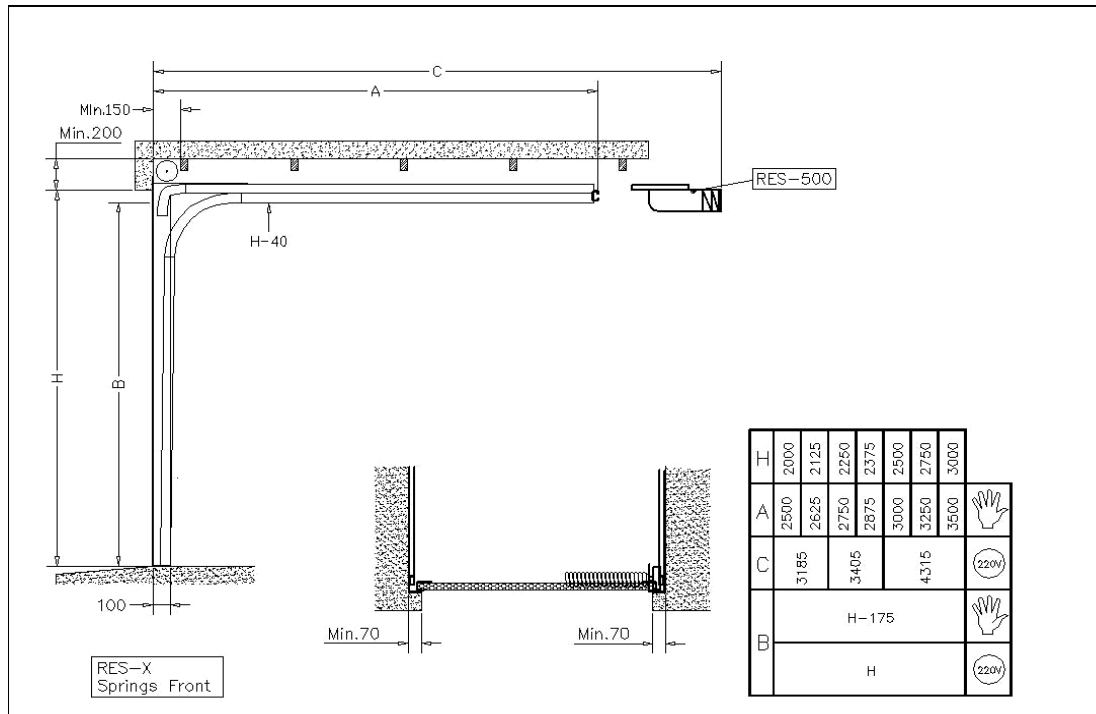

INSTALLATION OF VERTICAL TRACK SET

1

First mark "A" and "B" on both piers using a spirit level or water level hose and then mark "C". (Figure 1)

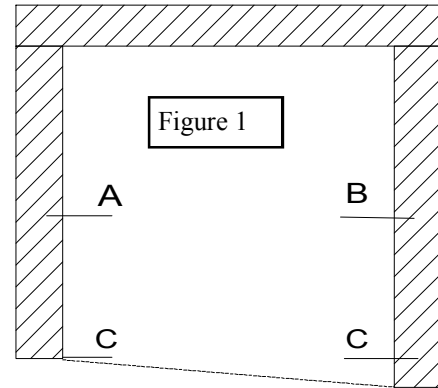

2

Prepare vertical tracks by fixing the weather seals before fixing the tracks

Fit both vertical tracks with the lower surface on mark line C and the edge 64 mm along the pennant (figure 2). The two bearing tracks should be parallel to one another.

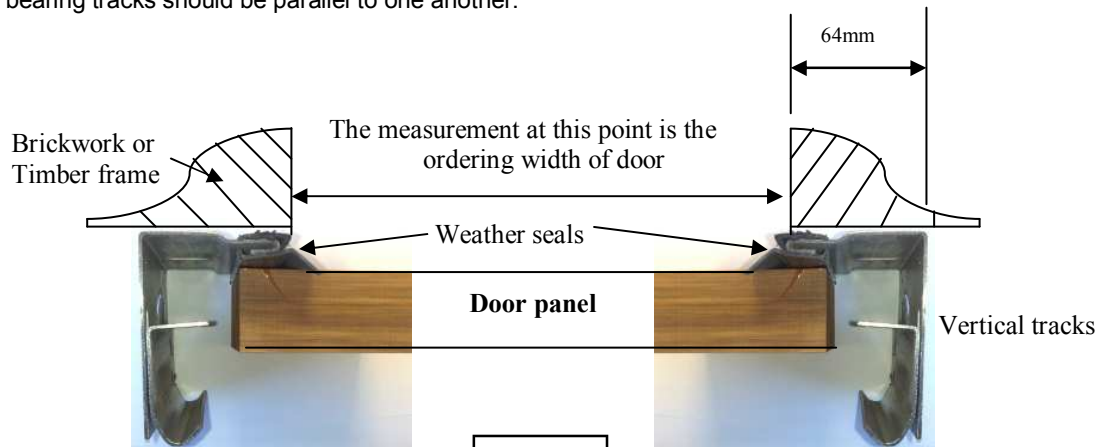

Figure 2

3

For sloping floors, one of the bearing tracks may be compensated (for example with a wedge)

IMPORTANT

ALL INSTRUCTIONS FROM NOW ON THAT ARE PREFIXED WITH **(F)** REFERS TO FRONT MOUNTED SPRINGS AND PREFIXED WITH **(R)** REFERS TO REAR MOUNTED SPRINGS

R4

INSTALLATION, ASSEMBLING CURVE PLATE, SPRINGS IN REAR (R)

If the curve plate is supplied fully assembled with the small upper curve fixed to it, **only** check if below mentioned actions are done in a proper way.

Assemble the curve plate:

- 1 position the small upper curve (picture in blue)for springs in rear. See picture. The short end of this curve is faced downwards.
- 2 fix the curve in the horizontal part with 2 bolts and 2 nuts to the side plate in the related holes (A).
- 3 Fix the lower curve to the side plate with 3 bolts and 3 nuts in the related holes.
- 4 Make sure that the flange of the vertical angle is placed between side plate and the small upper curve. Thus, the side plate is positioned on the outside of the vertical angle.
- 5 Now fix the vertical part of the small upper curve with 2 bolts and 2 nuts to the side plate and angle.

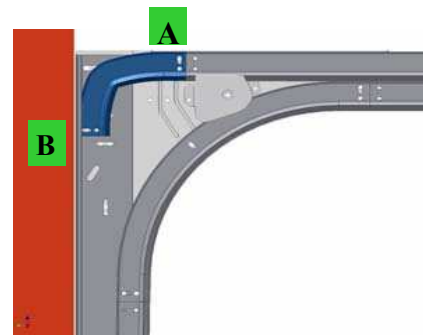

6

FITTING CABLE PULLEY AND BRACKET TO THE SIDE PLATE (R)

The side plate contains 3 major holes in which to fit a return pulley (A, B and C). See figure. The position on the cable pulley depends on the operation of the door (electric or manual) and the cable diameter. It is sufficient to use only 3mm cable for doors in this concept (<160kg, 5x3m). For installing the cable pulley and cover plate use following holes:

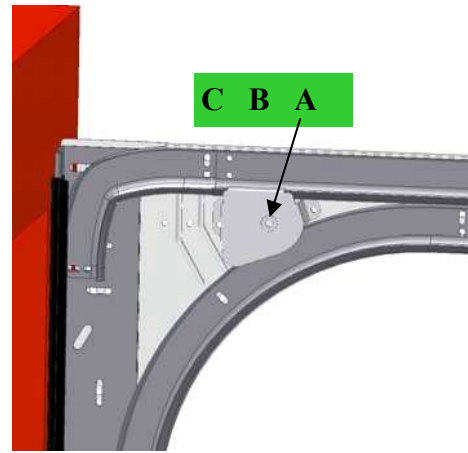

NB! For the fixation of the cover plate additional smaller holes are provided in the plate.

<u>Operation</u>	<u>Hole</u>
Manual operation	A
E-power operation	B

R5

Insert the M8 press bolt through the cover plate, the return pulley, the spacer and hole A, B (see Figure 3) of the reinforced end plate of the assembled curve plate. The spacer should be fitted with the flat side against the end plate. Fit the M8 nut and tighten it. Now fix the M6 bolts and nuts to fix to cover plate on two points.

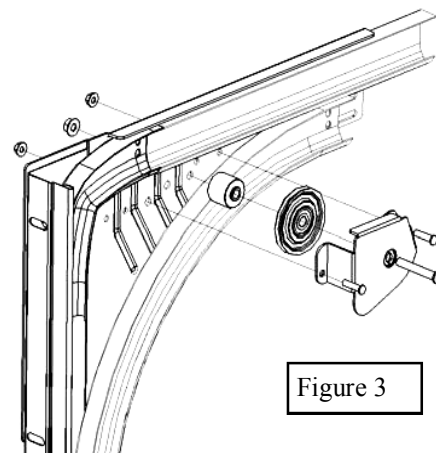

Figure 3

F4

If the curve plate is supplied fully assembled, with the small upper curve fixed to it, only check if below mentioned actions are done in a proper way.

Assemble the curve plate:

- position the small upper curve for springs in rear. See picture. The short end of this curve is faced downwards.
- fix the curve in the horizontal part with 2 bolts and 2 nuts to the side plate in the related holes (A).
- Fix the lower curve to the side plate with 3 bolts and 3 nuts in the related holes.
- Make sure that the flange of the vertical angle is placed between side plate and the small upper curve. Thus, the side plate is positioned on the outside of the vertical angle.
- Now fix the vertical part of the small upper curve with 2 bolts and 2 nuts to the side plate and angle.

Position the end of the curve in line with the vertical angle. Then fix the M6 flange nut and bolt through the hole.

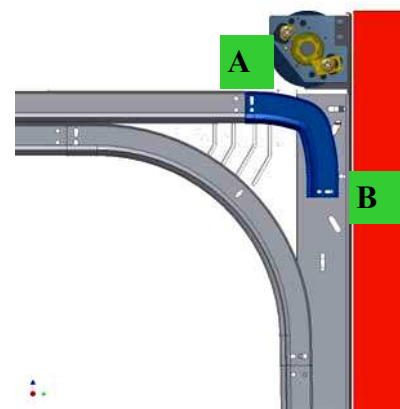

6 FITTING OF TOP WEATHER SEAL

Top weather seal as shown across is fixed to either the timber sub frame head frame or direct to the rear of the lintel by method of the steel fixing clips so the seal is allowed to hang down passed the top edge of the top panel

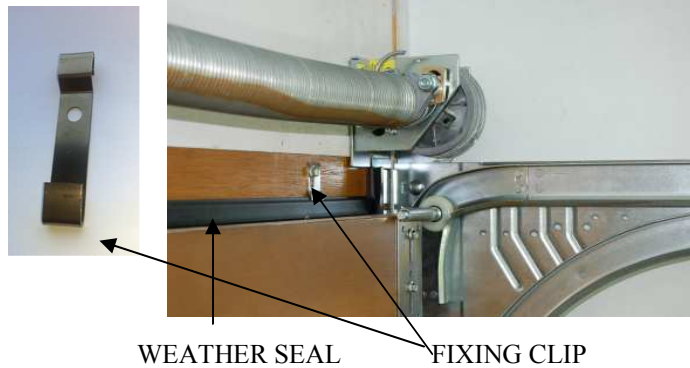

WEATHER SEAL FIXING CLIP

ASSEMBLY HORIZONTAL TRACK SET

7

Attach a piece of rope to the ceiling or the roof structure to maintain the elevation of the rear side of horizontal tracks during the assembly process.

8

Slide the horizontal tracks in the direction of the vertical track set (A).

9

Insert the 2 M6 press bolts from the inside through the holes in the upper track (1). Fit the M6 flanged nuts and secure hand tight.
Insert the 2 M6 press bolts from the inside through the holes in the lower track (2). Fit the M6 flanged nuts and secure hand tight.

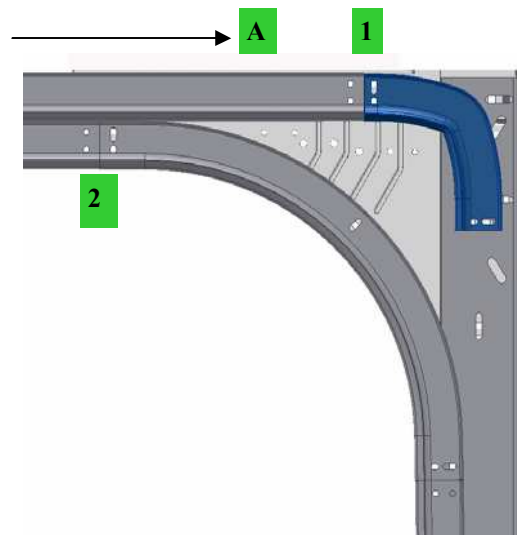

ASSEMBLY BEARING PLATE SUPPORT AND SPRING PACKAGE SPRINGS IN REAR (R)

R10

Fit the bearing plate support to the end of the horizontal tracks. The position of the bearing plate support relative to the horizontal tracks will depend on the height available for installation (see figure 4).

Position A: the position of the bearing plate support for an available installation space of at least 100 mm. Always for electrical drive and for manual operation when there is sufficient (>90 mm) height available.

Position B: the position of the bearing plate support for an available installation height

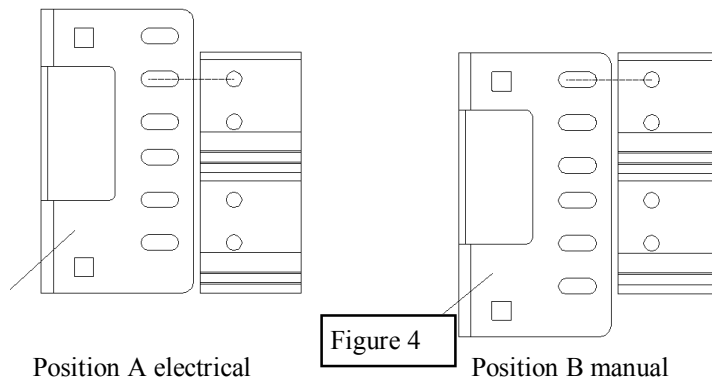

Position A electrical

Position B manual



SUSPENSION AND CONNECTION HORIZONTAL TRACKS

10

Depending on the selected options one of the following instructions will apply. Standard in Flexi-Force configuration of sets, the suspension is done with suspension bracket and track console. This is an ideal method for an intermediate track fixing.

Click console 3022D on the horizontal double track. Slide bracket 3021 in the hole between track and console. Mount the track console to the ceiling with proper fixing material, depending on the material of the ceiling. Adjust the height and angle of the horizontal track and secure this position with fixing the bolt and nut in the track console.

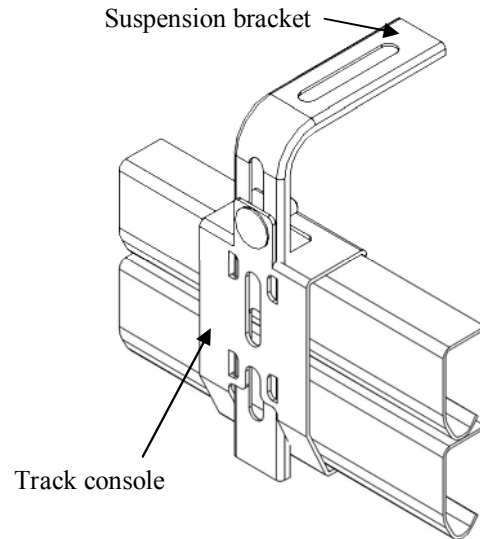

R10

With vertical suspension profile of horizontal tracks to ceiling or roof structure (springs rear R)

Fit the perforated angle (30B0750) to the bearing plate support (340) with 2 M8 press bolts and nuts (1070-3.5B and 1068M).

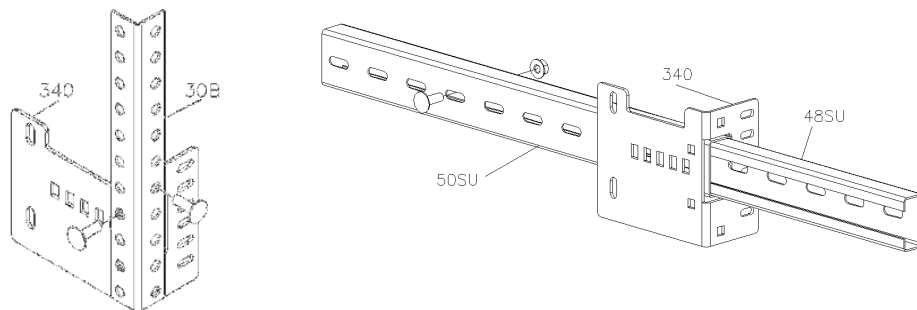

R10

With horizontal connecting profile between the horizontal tracks CW <3000 (springs rear R)

Shorten when necessary the long C profile. The profile may then be used as measuring rod ($L = \text{Clear Width} + 134 \text{ mm}$). The ends of the 50SU profile will then correspond with the exterior of the bearing plate support. Slide first onto both sides the short 48SU profile into the 50 SU profile. Then slide long C profile with slotted holes on both ends into the rectangular recess of the bearing plate support (340) as mutual connection. The closed side should rest on the flange of the bearing plate support (340).

R10

With horizontal connecting profile between the horizontal tracks CW >3000 (springs rear R)

Slide both C profiles into each other. Mark a length of $L = \text{CW} + 134 \text{ mm}$. This length is the external side of the bearing plate support. The closed side should rest on the flange of the bearing plate support (340). Connect the 50 SU profile to the bearing plate support (340) with 2 M8 mushroom bolts and nuts (1070-3.5B and 1068M). Then slide the short profiles (48SU) out until they reach a potential suspension point (sidewall) where they can be secured. Then secure finally the securing nuts of the connection between horizontal and vertical track set.

F10**With horizontal interconnecting profile between the horizontal tracks (springs in front F)**

Fit the angle bracket (2602) with 2x press bolt (1062B) and 2x flanged nut (1062M) to the end of the upper horizontal tracks.

F10**With horizontal interconnecting profile between the horizontal tracks CW up to 3000mm (springs in front F)**

Shorten when necessary the long 50SU profile. The profile may then be used as measuring rod ($L = \text{Clear Width} + 129 \text{ mm}$).

The ends of the 50SU profile will then correspond with the exterior of the angle bracket. Slide first onto both sides the short 48SU profile into the 50 SU profile. Then position the long 50SU profile with slotted holes on the angle bracket as mutual connection. The closed side should rest on the angle bracket. Connect the 50SU profile to the angle support with the M8 press bolts and nuts. Then slide the short profiles (48SU) out until they reach a possible suspension point (sidewall) to which a connection can be made.

**F10****With horizontal interconnecting profile between the horizontal tracks CW over 3000mm (springs in front F)**

Slide both C profiles into each other until the length required is realized and minimum overlap is 500 mm. Mark of a length of $L = \text{Clear Width} + 129 \text{ mm}$. This length is the external side of the angle bracket.

Then position the C profile with slotted holes (50SU2750) on the angle bracket (2602) as mutual connection. The closed side should rest on the angle bracket.

Connect the C profile to the angle support with the M8 pressed bolts and nuts (1070-3.5B en 1068M). Secure the C profile to any suspension point (sidewall) involved.



ASSEMBLY AND FITTING OF SPRING PACKAGE SPRINGS IN REAR (R)

R11

For doors up 3000mm W x 2500mm H

Slide the tube shaft (701...) through both springs. The tension plug of the anti-clockwise wound spring is coded black and should be fitted on the left. See figure below.

Fit shaft support off centre when a electric operator is to be used

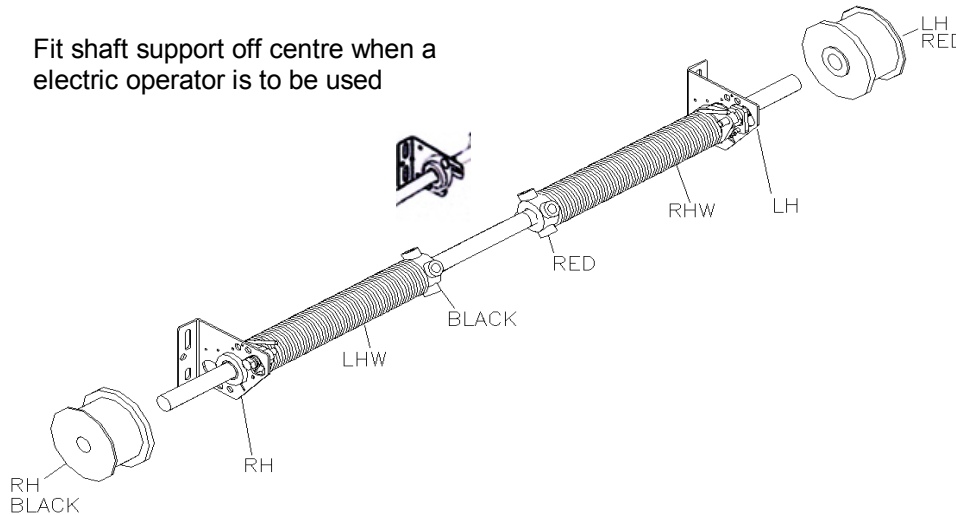

Fit the spring breaking devices (651LH/Rhor 667LH/RH) to the stationary spring plugs, following the drawings that are included in the packaging with every spring breaking device.

! See handbook enclosed for the 651/667 spring breaking device.

R11

For doors from 3000mm W x 2500mm H to 3000mm W x 3000mm H

Slide the key-keyed tube shaft through both springs. The tension plug of the anti-clockwise wound spring is coded black and should be fitted on the left. See figure above.

R11

For doors up to 5000mm W x 3000mm H

Slide each of the two key-keyed tubular shafts through a spring. Cut the tube shafts of unequal lengths to avoid the coupling from the centre, and when there is an electric drive, sitting under the drawbar.

The tension plug of the left-wound plug is coded black and should be fitted on the left. See figure. Fit to both shafts a bearing and a bearing retainer each with 2 M8 press bolts and nuts to the bearing plate.

Then fit disassembled halves of the coupler with a cotter



Fit the spring breaking devices (651LH/Rhor 667LH/RH) to the stationary spring plugs, following the drawings that are included in the packaging with every spring breaking device.

! See handbook enclosed for the 651/667 spring breaking device.

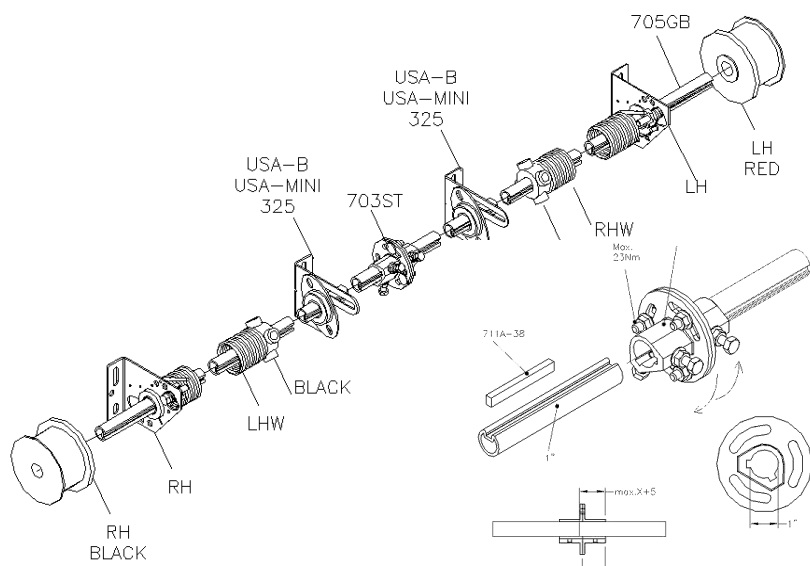

R12

Fit the spring breaking devices (651LH/RH or 667LH/RH) to the stationary spring plugs, following the drawings that are included in the packaging with every spring breaking device. **! See installation manual for the 651/667 spring breaking device for details and warnings! The fixation of the pall-wheel to the shaft should be done by pre-drilling a hole in the shaft!**

R13 Doors up to 3000mm wide

Slide on both sides a cable drum (single door or double door) onto the shaft. The cable drum coded RH, should be fitted on the left side. Turn the securing bolts of the cable drum (single door) to secure these hand-tight to the tube shaft. Secure each cable drum (double door) with a key on slotted shaft

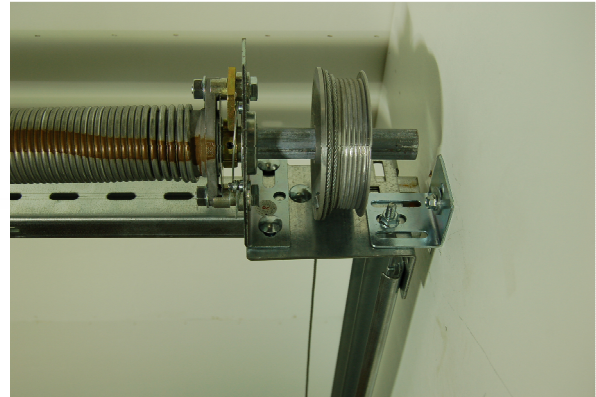
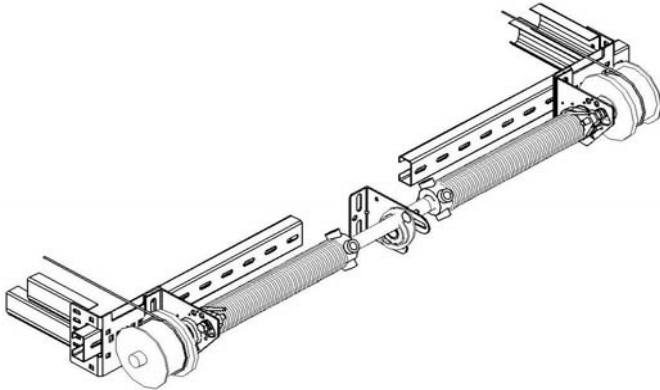

R13 Doors up to 3000mm wide

Fit the bearing plates with spring breaking device with shaft and spring package in conformity with figure below to the bearing plate supports, each with 2 M8 press bolts/nuts (1070B3,5 and 1068M) and the bearing plates each with 1 press bolt and nut (1070B3,5 and 1068m).

See for correct position figure on next page. The position of the bearing plate relative to the bearing plate support will depend on the available installation height.

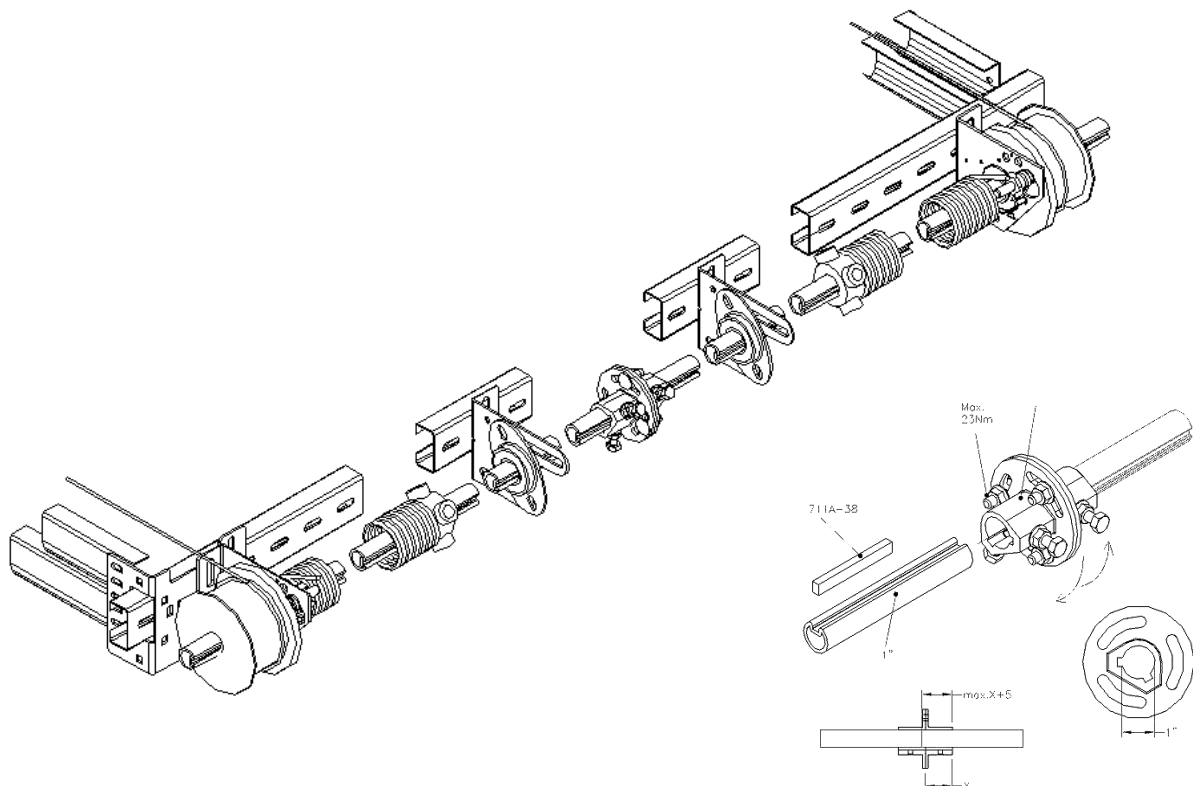

Position A: the position of the bearing plate support for an available installation height of at least 100 mm. Always for electrical drive and may be possible for manual operation (illustration 220V).

Position B: the position of the bearing plate support for an available installation height between 70 and 100 mm. In many instances for manual operation (illustration hand).

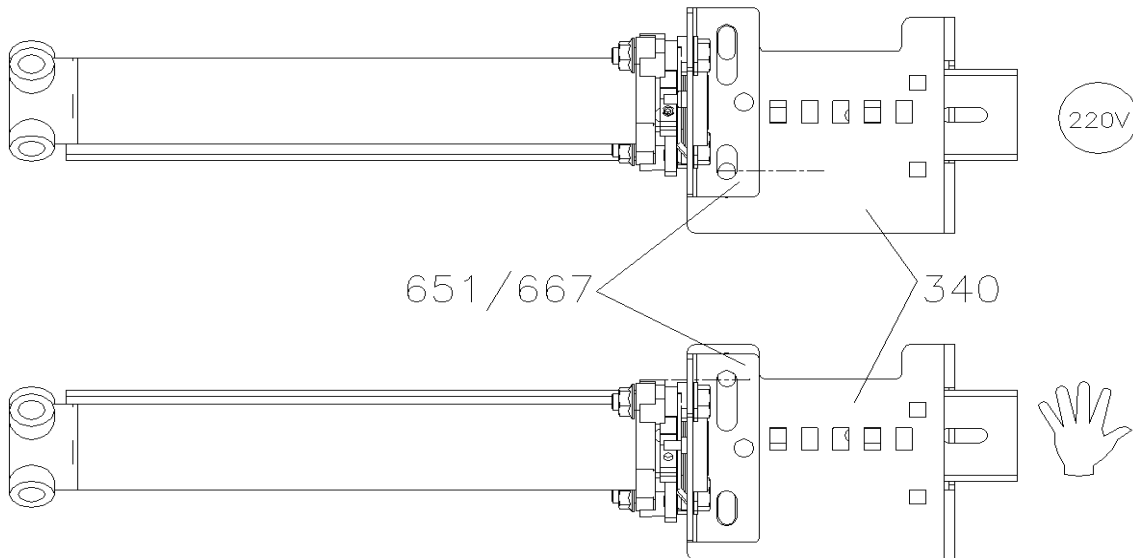

ASSEMBLY AND FITTING OF SPRING PACKAGE SPRINGS IN FRONT (F)

F11

For doors up to 3000mm W x 2500mm H

Slide the tube shaft through both springs. The tension plug of the anti-clockwise wound spring is coded black and should be fitted on the left. See figure below.

F11

For doors from 3000mm W x 2500mm H to 3000mm H

Slide the key-wayed tube shaft through both springs. The tension plug of the anti-clockwise wound spring is coded black and should be fitted on the left. See figure below.



! IMPORTANT ! SEE INSTALLATION OF 651/667 SPRING BREAK DEVICE THAT ARE INCLUDED IN THE PACKAGING

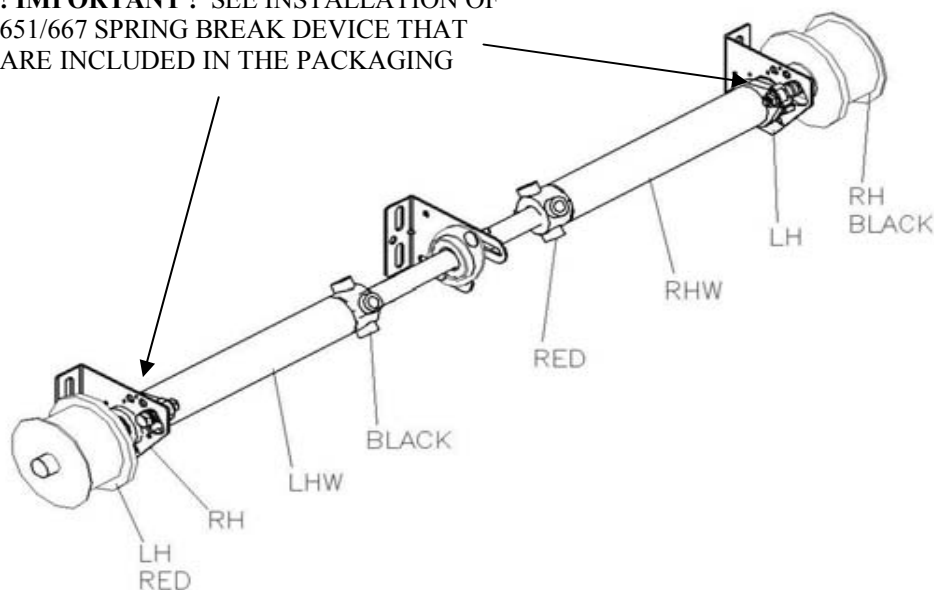

F12

For doors up to 5000mm W x 3000mm H

Slide each of the two key-wayed tube shafts through a spring. The tube shafts are of unequal lengths to avoid the coupling (703ST) from the centre, and when there is an electric drive, sitting under the drawbar. The tension plug of the left-wound plug is coded black and should be fitted on the left. See figure 8a. Fit to both shafts a bearing and a bearing holder each with 2 M8 pressed bolts and nuts to the bearing plate (USA-MINI). Then fit disassembled halves of the coupler (703ST) (711A-38).

F13

Fit the spring break devices (651LH/RH or 667LH/RH) to the stationary spring plugs, following the drawings that are included in the packaging with every spring break device.



! See installation manual for the 651/667 spring breaking device for details and warnings! The fixation of the pall-wheel to the shaft should be done by pre-drilling a hole in the shaft!

Slide on both sides a cable drum (FF-4X8 or FF-4-13) onto the shaft. The cable drum coded RH, should be fitted on the left side. Turn the securing bolts of the cable drum to secure these hand-tight to the tube shaft. Secure each cable drum FF-4-13 with a cotter (711A-75).

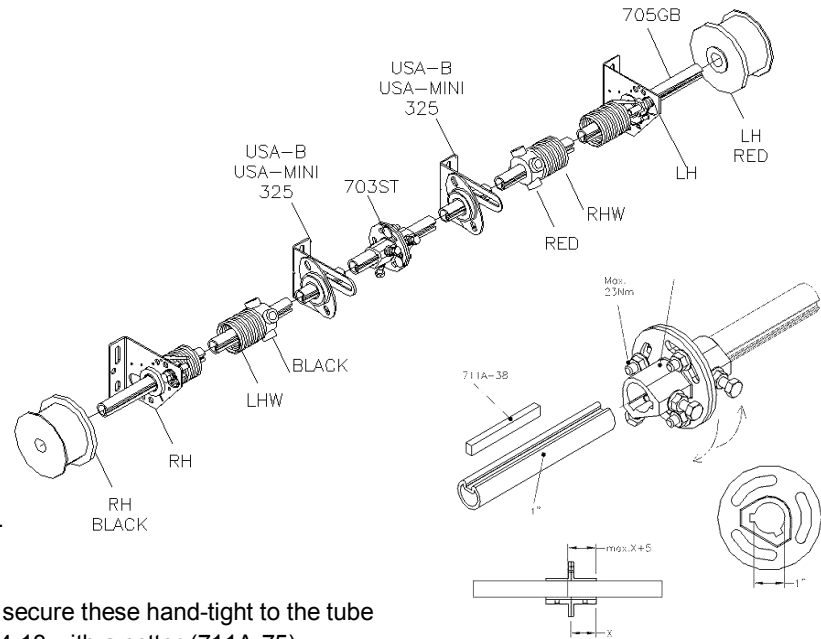

F14

To install the spring breaking devices to the lintel, use the special designed support bracket, article code **RX563L/R**. Fix the spring breaking device to this bracket. Position the assembled shaft and connect the bracket to the side plate with bolt and nut. Install the center bearing plate USA-MINI to the wall.

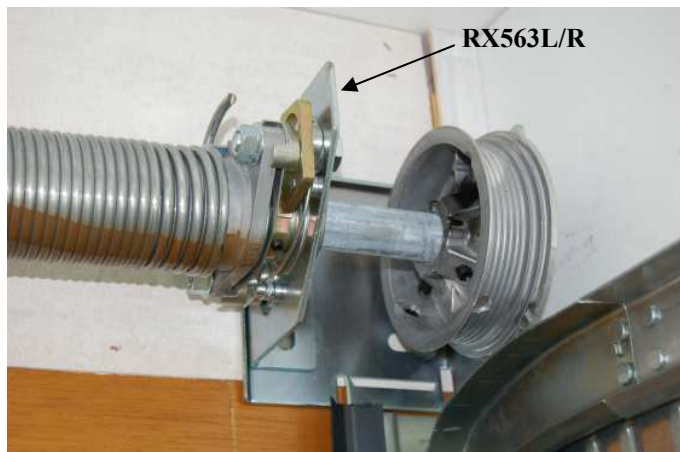
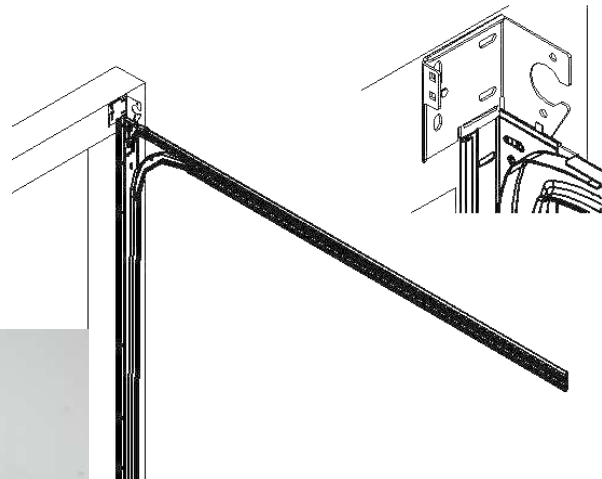

FITTING OF THE DOOR PANELS

15 General

The door panels will be delivered in 2no shrink-wrapped packages each with 2 sections of the door face to face together being separated with a layer of bubble wrap cut away the shrink wrapping carefully taking care not to cut the timber panels, you will find a plywood strip screwed the bottom edge of some of the panels this is to protect the grooved out section of the joining panels from transit damage.

You will also find pre fitted to the panels all side and intimate hinges, bottom roller brackets and bottom weather seal, so the door can be unwrapped and installed into to opening ready to have the rollers fitted, the top roller brackets can only be fitted once all the panels are in place and lined up correctly.

Important When installing the panels into the opening place a piece of cardboard between the panels to provide the correct spacing's between the panels if is not done the timber panels could bind and creek due to Expansion.

R15 Installing bottom panel springs at rear (R)

The bottom panel will have the bottom roller bracket and carrier fixed in place you will need to remove the carrier to install the panel, position the panel between the vertical tracks and up against the seals, the panel must sit level.

R16

Insert the shaft of the bearing roller (577) through the loop of the lifting cable (k3x../k4x...) until the loop rests in the recess in the shoulder of the bearing roller shaft. Insert the shaft of the bearing roller in the bearing roller holder (447S).

Click the roller protection (580CEN or 581CEN) onto the roller. Place the roller carrier with roller on the 2 protruding M6 pressure bolts of the bottom bracket and secure them with 2 M6 flanged nuts (1062M). See Figure 5.



NB! Make sure that the bottom panel will not be cut for adjusting the panel or door height. This should be done with the top section only! The attachment of the bottom bracket, which is holding the complete door weight, is relying on the construction of the panel. Danger can occur if the panel is cut at this point.

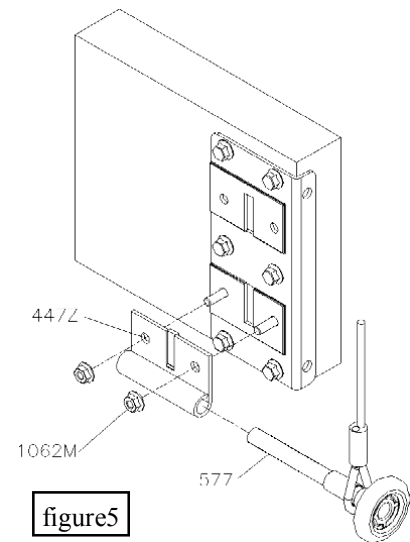

INSTALLING BOTTOM PANEL SPRINGS IN FRONT (F)

16 General

The door panels will be delivered in 2no shrink-wrapped packages each with 2 sections of the door face to face together being separated with a layer of bubble wrap cut away the shrink wrapping carefully taking care not to cut the timber panels, you will find a plywood strip screwed the bottom edge of some of the panels this is to protect the grooved out section of the joining panels from transit damage.

You will also find pre fitted to the panels all side and intimate hinges, bottom roller brackets and bottom weather seal, so the door can be unwrapped and installed into to opening ready to have the rollers fitted, the top roller brackets can only be fitted once all the panels are in place and lined up correctly.

Important When installing the panels into the opening place a piece of cardboard between the panels to provide the correct spacing's between the panels if is not done the timber panels could bind and creek due to Expansion.

F16

The bottom panel will have the bottom roller bracket and carrier fixed in place, position the panel between the vertical tracks and up against the seals, the panel must sit level.

F17

Hook the loop of the lifting cable (k3x or k4x) to the pin intended for that purpose on the bottom bracket. First click the roller protection (580CEN or 581CEN) onto the roller.

Insert the shaft of the bearing roller (590-25) through the spacer (2066-07) and the holes of the bottom bracket (422LH/RH) intended for that purpose. Place then the bearing roller first in the bearing track and then secure the bottom brackets with the self-tapping screws (1055BV). See figure.

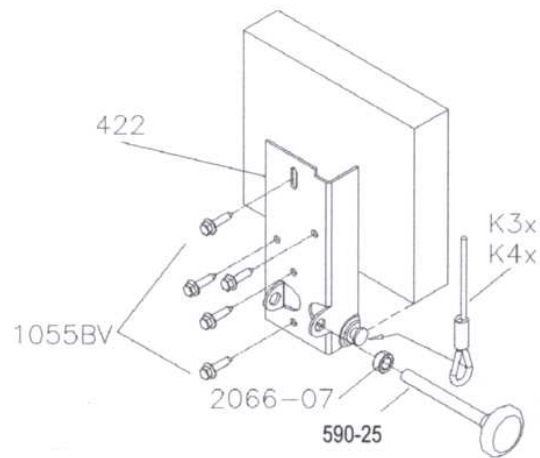

PLACING PANELS

18

Place (stack) the remaining panels and secure the upper leaf of the side and central hinges to the panels.

Important When installing the panels into the opening place a piece of cardboard between the panels to provide the correct spacing's between the panels if is not done the timber panels could bind and creek due to Expansion.

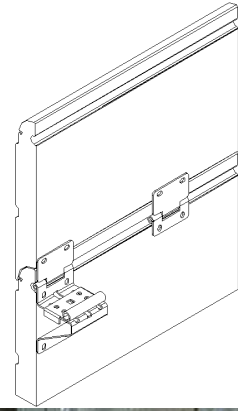

19

Adjust the roller to the side hinge such that the nylon of the roller is located in the rounding of the track and that the play between panel and side seal is at a minimum. The shaft of the bearing roller should remain capable of turning by hand. Fix this position by fixing the slide (roller carrier) onto the base of the side hinge by means of 2 bolts (1062B) and two nuts (1062M). First click the roller protection (580CEN or 581CEN) onto the roller.



INSTALLATION TOP ROLLER CARRIER SPRINGS IN REAR (R)

R20

Slide the plastic bush (418BUS) over the bush of the top roller holder (418LH/RH). Then slide the shaft of the roller (576) into the bush of the top roller holder (See figure).

R21

Place the roller in the small upper bend and fix the top roller holder (418LH/RH) to the upper side of the top panel with 2 self-tapping screws (1055BV) in both slotted holes. The remaining self-tapping screws (1055BV) will be secured at a later stage. The position of the top roller in the small curve is determined by the operation:

Position A = manual operation (top panel is locked when door is closed)

Position B = power-operation (e-operator can draw the roller into the horizontal track).

NB! Do not install a 580CEN roller protection on the top roller!

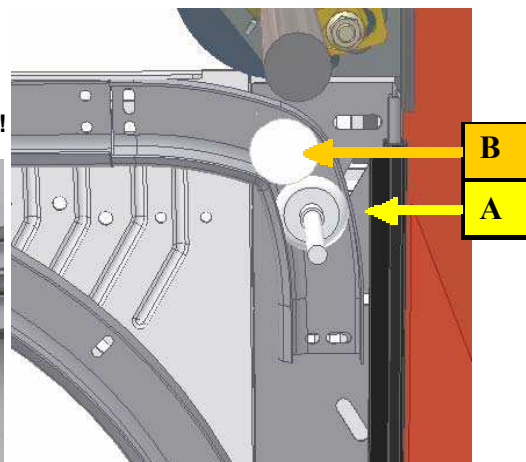
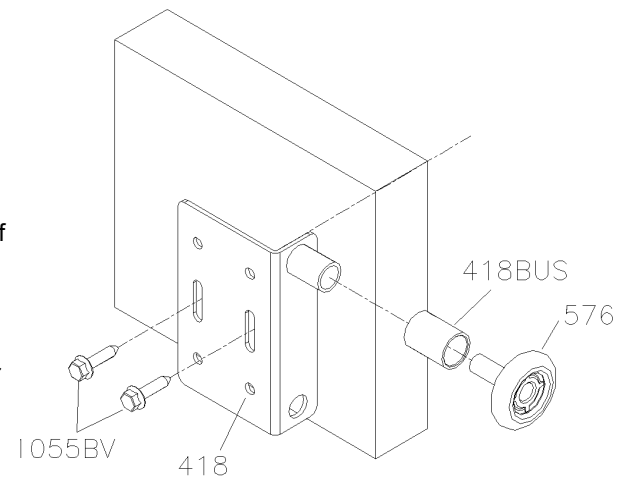

INSTALLATION TOP ROLLER CARRIER SPRINGS IN FRONT (F)

F22

Slide the shaft of the roller (590-25) through the spacer (2066-10) into the sleeve of the top roller carrier (see figure).

F23

Place the roller in the short curve and fix the top roller carrier (417) to the upper side of the top panel with 2 self-tapping screws (1055BV) in both slotted holes (figure). The remaining self-tapping screws (1055BV) will be secured at a later stage.

The position of the top roller in the small curve is determined by the operation:

Position A = manual operation (top panel is locked when door is closed)

Position B = power-operation (e-operator can draw the roller into the horizontal track).

NB! Do not install a 580CEN roller protection on the top roller!

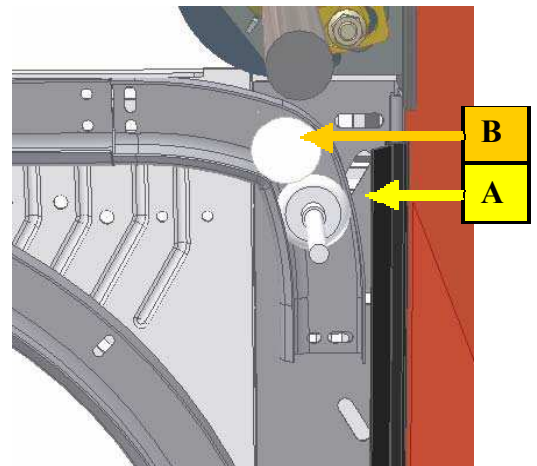
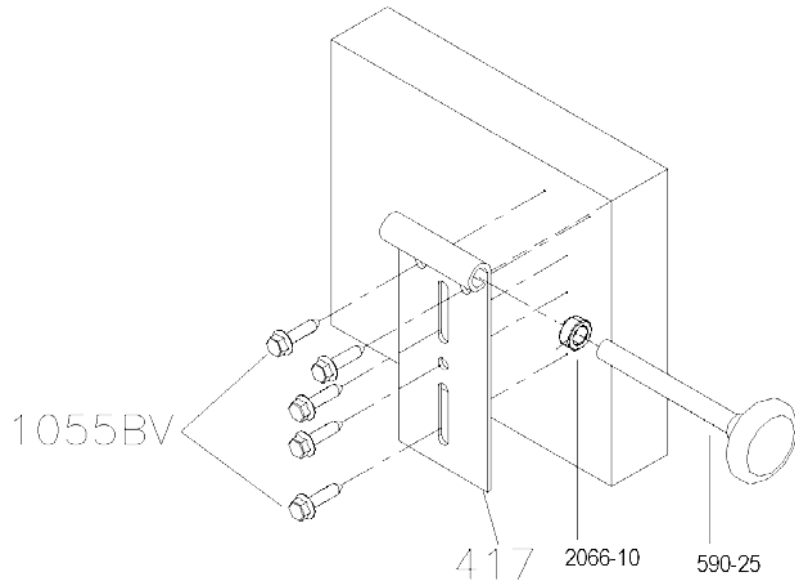

FITTING CABLE AND TENSIONING THE SPRING PACKAGE SPRINGS IN REAR (R)

R24

Align the shaft. Grease the cables.

R24

Guide the cable from the bottom bracket, behind the bearing roller shafts and over the return pulley to the cable drum. See figure >.

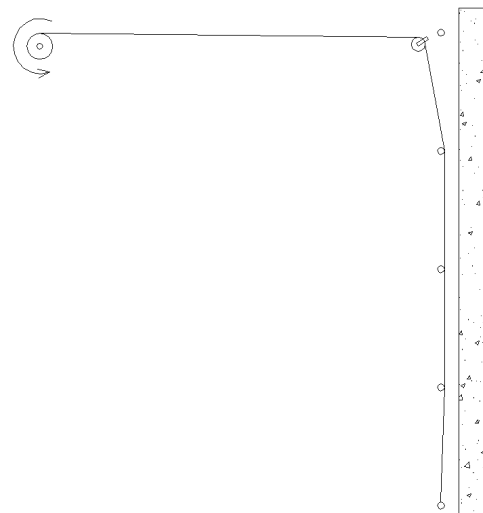

R24

Hook the end of the cable with the end of the pressure clamp (circular) into the cable drum and turn the cable drum until the lifting cable is taut.

R24

Align the cable drum in such fashion on the tube shaft that the lifting cable is free to wind up through the recess in the bearing plate (see figure 21) and the cable cannot interfere with the plastic bush (418BUS). Secure finally the drum (FF-4X8) with the hexagon bolts to the shaft (without keyway) (tightening moment 10Nm). For a tube shaft with a keyway the drum (FF-4-13) must be secured with a cotter (711A-75) and bolts (tightening moment 10Nm).

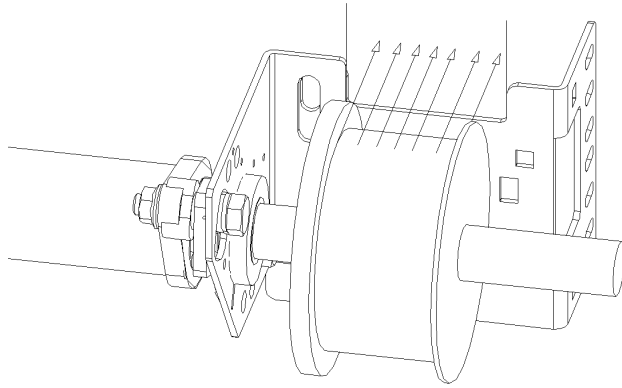

FITTING CABLE AND TENSIONING SPRING PACKAGE SPRINGS IN FRONT (F)

R25

Align the shaft.

R26

Guide the cable from the bottom bracket, behind the bearing roller shafts to the cable drum. See figure>

Hook the end of the cable with the end of the pressure clamp (circular) into the cable drum and turn the cable drum until the lifting cable is taut. Align the cable drum in such fashion that the lifting cable is free to wind up. Secure finally the drum (FF-4X8) with the hexagon bolts to the shaft without keyway (tightening moment 10Nm). For a tube shaft with a keyway the drum (FF-4-13) must be secured with a cotter (711A-75) and bolts.

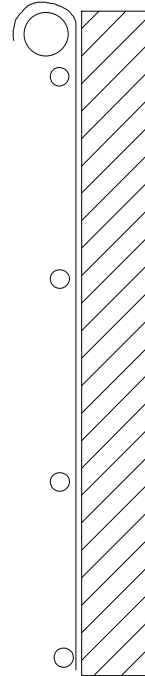
**27**

Block the shaft with for example a wrench.

28

Secure the other cable in the same fashion. Both cables must be tensioned equally while the door panel is truly level.

**29**

Ensure that the door does not elevate. You can do this for example by placing wrenches in the vertical bearing tracks.

NB! Make sure the wrenches are secured tightly.

**CAUTION!**

Torsion springs are subject to considerable tension.

Proceed at all times with extreme caution.

Installation, maintenance and repair should be carried out only by experienced and properly trained overhead door fitters.

Use correctly fitting and properly maintained tension levers (spanners) See attachment.

30

Tension the springs by the prescribed number of turns (see table below), pull the spring ± 5 mm apart (to reduce friction) and secure the spring to the tube shaft using the screws of the tension plug (17 Nm). For a shaft with key-way, one of the screws should be positioned in the key-way.

Number of turns spring	
Opening height	turns each spring
2000	7.2
2125	7.8
2250	8.1
2375	8.5

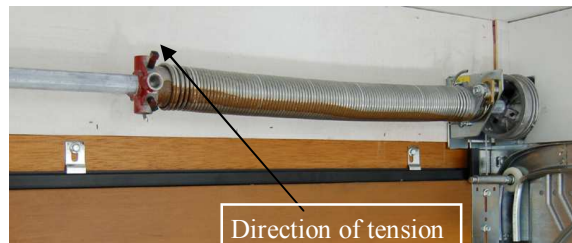

Tensioning the spring (read fully below before attempting to tension the spring)

Important To apply tension to the springs the spring tensioning plug must be turned in the opposite direction to which the shaft will turn when lifting the door

1. Make sure that the marking strip on the spring forms a sharp line
2. Insert the 1st tension lever completely into the tensioning slot
3. Turn the 1st tension lever a quarter turn such that the spring is tensioned
4. Insert the 2nd tension lever completely into the following tensioning slot
5. Take over the tension of the spring from the 1st tension lever to the 2nd lever
6. Remove the 1st tension lever from the slot
7. Turn the 2nd tension a quarter of a turn such that the spring is tensioned
8. Repeat steps 2 through to 7 until the spring has realized the prescribe number of turns
9. Secure the spring plug on the shaft by turning the bolts in the tension plug in the tube shaft
10. Remove the final tension lever
11. Check the number of turns by counting the number of turns that the marking strip has made

31

Remove the restriction from the door in the tracks and from the shaft and check whether the door is properly balanced. When this is not the case you should correct this by tensioning or relaxing by at most 1 turn per spring. Make sure when doing this that both springs are equally corrected.

32

Correction of the spring tension

- a. Insert the 1st tension lever completely into the tension slot.
- b. Take over the tension from the spring with this tension lever.
- c. Loosen the bolts in the tension plug.
- d. Turn the 1st tension lever in the direction required.
- e. Insert the 2nd tension lever completely in the next tension slot.
- f. Take over the tension of the spring from the 1st tension lever to the 2nd tension lever.
- g. Remove the 1st tension lever from the slot.
- h. Turn the 2nd tension lever a quarter turn in the direction required.
- i. Insert the 1st tension lever completely into the next tension slot.
- j. Take over the tension of the spring from the 2nd tension lever to the 1st tension lever.
- k. Repeat steps 4 through 10 until the correction required has been realized.
- l. Secure the spring plug on the shaft by turning the bolts in the tension plug in the tube shaft.
- m. Remove the final tension lever.

33

When the door panel is not hanging completely horizontally in the lifting cables in (almost) closed condition there are three options for fine adjustment.

A Tube shaft, opened door: Rotate the drum opposite of the shaft.
Loosen the securing bolts of the cable drum and rotate the drum relative to the tube shaft. For slight movements there is always a risk that the securing bolts 'slide' into the same shallow in the tube shaft and the adjustment is not improved. Tighten again the bolts.

B Key-wayed tube shaft: When a coupler is used (703ST) loosen the bolts of the coupler, rotate both

C Springs in front (F): Slightly loosen the fixation of the shaft suspension to the wall. Move the brackets

C Springs in rear (R): When the connection/suspension profile behind the horizontal tracks has not been finally adjusted the bearing plate support in the slotted holes may be adjusted relative to the horizontal tracks.

34

Close the door and secure the door panel with a wrench. Loosen the two self-tapping screws (1055BV) securing the top roller holder so that it can be displaced with a slight tick. Press the top panel against the side (upper) seal and slide the top roller holder in such a position that the roller is placed in the roundings of the curve. There must be minimum play between door panel and seal.

See, picture:

For a manually operated door the bearing roller should be displaced downwards. The bearing roller lies snugly in the vertical part of the small curve. For an electrically driven door the bearing roller should be displaced upwards. The bearing roller lies snugly against horizontal side of the curve. Then secure the 2 self-tapping screws. When the top panel cannot from outside be pushed inwards, the remaining self-tapping screws may be secured.

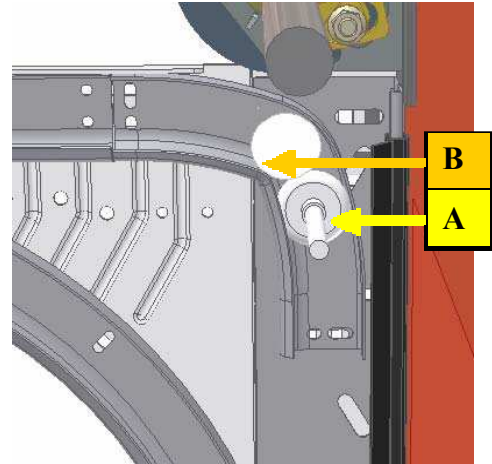

FINISHING THE DOOR

35

Install any additional accessories that you have ordered separately such as: Handgrip, lock, slide bolt, etc. See attachment for build-in instructions.



NB! A slide bolt may not be fitted to an electrically driven door.

NB! A manually operated door should always be equipped with a hand grip, installed at a safe location on the door.

NB! Only lock 650 may be employed when springs are in the rear (R) because it does not touch the cable.

NB! The minimal build-in dimensions are effected by a lock. The knob is reaching outside the panel.

NB! For safety reasons always install the grip in the center of a door. In that way, when opening the door manually, there is less risk of injuring hands between de track and rollers!

36

To position the rubber door stop (2100-15), open the door completely. Drill a hole of 6,5mm. Fit the rubber doorstop (2100-15) supplied with a press bolt M6x16 (1062B) and nut M6 1062M), to the end of the top horizontal tracks (Figure >).

37

Oil all hinges and all bearing rollers with one drop of oil (WD40).

38

Greasing of the cables is already done during installation.

39

Let some drops of oil go into the curve of the track. This lubricates the connection between track and nylon roller, which allows a smooth operation of the door.

40

The roller shafts are being greased during installation.

41

The torsion springs are already lightly oiled.

42

Place your CE identification plate on the door (mandated!!) together with any warning labels required (LABEL-GB). On the backside Flexi-Force LABEL-GB sheet you can find instructions on where to place the labels.



NB! Place a warning label on the lower curve because fingers or hands could be trapped between curve and panel when the door is moving.

Hand over necessary documents to the end-user:

- 1 User manual
- 2 Dismantling instructions (included in this manual)
- 3 Maintenance instructions (included in the user manual)
- 4 Service log book
- 5 Declaration of conformity Ila declaring the door is according to EN-13241-1.

Visit www.cedardoor.co.uk for more information on your obligations towards handing over a safe-to-use door.



NB! WITH THIS DOOR NO ROPE IS BEING SUPPLIED. DO NOT INSTALL A ROPE WITH A POWER OPERATED DOOR AT ANY TIME!! THIS CAN CAUSE SERIOUS INJURIES OR DANGER TO THE USER OF THE DOOR!

OPTION ELECTRICAL DRIVE

When you have selected an electrical operator drive (RES-E-500 or other), then this should be assembled in conformity with the handbook supplied with this operator. You should clearly follow the instructions for electrical operation in this handbook.

In order to maintain the closing peak force of the door within the CE-standards set the attachment point (97014) of the drawbar should be fixed at the proper position from the upper hinge point. Ask your supplier for the correct position.!



NB! The person installing the door must check thoroughly if the combination between this door and the selected operator is safe to use. Keep in mind the max. peak force that is allowed when closing the door. People could get hurt if the adjustment of the operator software, or the installation of the operator or the selected operator on this door, are not checked correctly!!